

MODEL #	26057T	26058T	26067T	26068T
MIL-DOT MODEL #	26157T	26158T	26167T	26168T
Magnification, x	3	4	3	4
Objective lens diameter, mm	50	60	50	60
Electronic-optical intensifier, generation	2+	2+	2+	2+
Electronic-optical intensifier, type	EPM66G-2*	EPM66G-2*	DEP XX1441*	DEP XX1441*
Resolution, lines/mm, min.	45	45	45	45
Field of view, deg	13	11	13	11
Maximum detection range in normal nighttime conditions - 0.05 lux (quarter moon), m	700	800	700	800
Diopter setting, D	±3.5	±3.5	±2.5	±2.5
Close-up range, m	5	8	5	8
Battery type, voltage	1 AA, 1.5V or 1 CR 123, 3V			
Battery life with continuous use with IR off, hr (AA ** / CR 123)	15/24	15/24	15/24	15/24
Battery life with continuous use with IR on, hr (AA** / CR 123)	5/8	5/8	5/8	5/8
Eye relief distance, mm	50	50	53	53
Water intrusion rating	IPX6	IPX6	IPX6	IPX6
Operating temperature range	-30 °C to +40 °C			
Dimensions, mm:				
Length	278	320	257	288
Width	95	95	95	95
Height	103	103	103	103
Weight without the mount, kg	≈1,0			
Compatibility with NVRS 2.5x50 attachment	Yes	No	Yes	No

* The riflescopes use these or similar electronic-optical intensifiers.
 ** We recommend using Alkaline batteries as they have a longer life.

- PACKAGE CONTENTS:**
- Assembled riflescope
 - Carrying case
 - Remote control
 - User manual
 - Warranty card
 - Weaver rail for digital camera adapter (supplied for riflescopes with Weaver mount only).

For improvement purposes, design of this product is subject to change.

DISTINGUISHING FEATURES OF THE PHANTOM

- Five (three - if EMP66G-2 tube employed) readily available configurations of illuminated red-on-green reticles that are able to be switched at a moment's notice
- Functions with one AA (1.5V) or CR-123 (3V) battery
- Accurate internal front lens focus adjustment
- Lightweight and highly durable; manufacturing employs carbon plastic and other modern technologies
- High magnification, 3x or 4x
- Close observational range of 5 meters
- IPX6 rating against water intrusion
- Shockproof with the use of heavy recoil ammunition (.375 H&H, .416 Rigby, .50 cal.), up to 6000 joules
- Vertical positioning of the battery ensures an uninterrupted power supply when firing
- The image intensifier tube is protected against excessive light exposure
- Incremental reticle brightness adjustment
- The reticle will blink as a warning 15-30 minutes before the device shuts down automatically as a low battery indicator
- Stabilized power supply for optimal consumption, ensuring no shift of the aiming point under a continuous power draw or drop in temperature
- Fast start-up
- Ergonomic design; the adjustment controls are located on top
- Precision internal windage/elevation adjustment MOA per click
- Built-in high-power PULSE hazard free IR illuminator with beam focus
- Remote control with secure attachment

- Additional weaver MIL-STD-1913 rail for accessories
- Flip-up objective lens cover
- Stylish carrying case
- Optional accessories provide photo and video recording

The PHANTOM is a complex electro-optical device designed using innovative technology. We strongly recommend reading and following all the instructions carefully before turning on the riflescope.

Not following the instructions and guidelines outlined in this instruction manual can cause damage to the device, as well as voiding any applicable warranty.

OPERATING INSTRUCTIONS

The PHANTOM night vision riflescope is intended for observation and hunting at dusk or during nighttime hours. When operated in conditions without artificial sources of light, it is a passive device. However, in environments of absolute darkness the built-in IR illuminator provides viewing ability. The PHANTOM is a very capable night vision device, and equally serves the amateur or professional for:

- Night observation and hunting
- Patrolling and safeguarding
- Search and rescue

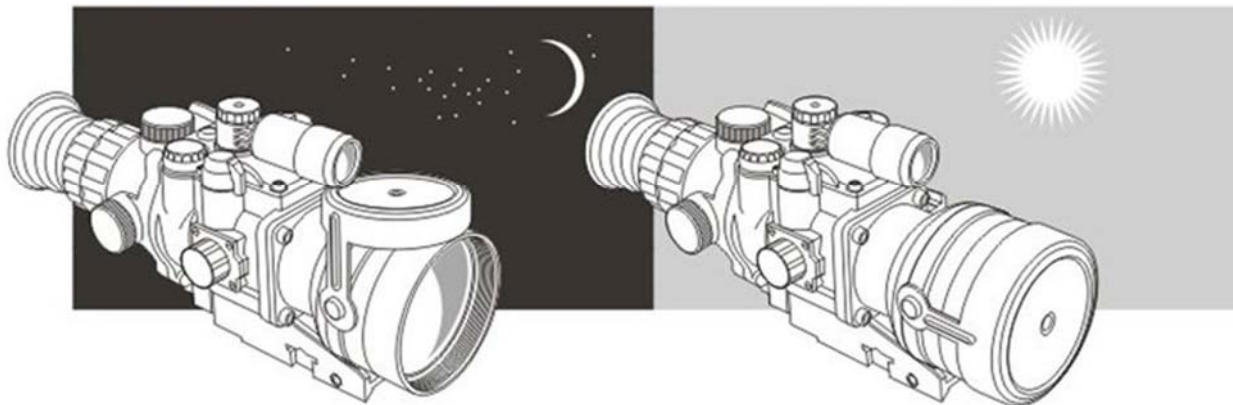

GUIDELINES FOR OPERATION

The PHANTOM has been designed for extensive usage. To ensure longevity and performance, it is necessary to adhere to the following:

- Under illuminated conditions measuring more than 1 lux (deep dusk), do not power on the riflescope with the objective lens cap open and do not point the product towards a direct light source! Daylight, vehicle headlights, flame, sun or similar light sources can irreversibly decrease its performance.
- Some examples of common illuminated conditions:

Conditions	Natural illumination in the field, lux
No moon, cloud cover	10^{-4} (0.0001)
Starry sky, no moon, clear	10^{-3} (0.001)
Quarter moon, clear	0.05
Full moon, clear	$0.38 \approx 0.4$
Deep dusk	1.0
Dusk	10
Cloudy weather	500

- When using in bright conditions (early morning or late evening), do not leave the device on with the objective lens cap open for more than 30 minutes. Continuous observation of bright stationary objects can cause the electronic-optical converter to fade, leading to the appearance of dark spots in the field of vision.
- Do not forget to turn off the scope after each use!
- Store with the lens cap on, in the accompanying carrying case.
- The scope has been reinforced with an IPX6 rating against water intrusion and can be used in inclement weather; however, it is not intended for full submersion.
- Attempting to disassemble or repair the scope will void the warranty!
- Clean the scope's optical surfaces only if necessary, and use caution. First, remove (by blowing or carefully wiping off) any dust or sand particles. Then proceed to clean by using a soft cotton tissue and alcohol or a cleaning solution approved for use with multicoated lenses. Do not pour the solution directly onto the lens!
- The scope can be used in operating temperatures, ranging from -30°C to +40°C. However, if it has been brought indoors from cold temperatures, do not turn it on for 3 to 4 hours.
- If the riflescope is unable to mount onto the rifle securely, or if there are doubts about the mounting system, see a qualified gunsmith. Using the weapon with a poorly mounted scope can lead to inaccurate target shooting!
- To ensure reliable performance, it is recommended to carry out regular technical inspections of the unit.

BATTERY INSTALLATION

- Unscrew the cap (1) of the battery compartment counter-clockwise.
- Install one AA (1.5V) or CR 123 (3V) battery, so that the (+) and (-) match the markings on the body of the unit.
- Tighten the cap (1).

OPERATING THE PHANTOM

- Install the batteries according to the directions in the section entitled “BATTERY INSTALLATION”.
- Enter a dark environment.
- Remove the objective lens cap by sliding it up on top of the objective lens (2).
- Turn on the unit by turning the selector switch (3) to the “ON” position; you will see the screen of the electronic-optical converter light up green.
- The scope can also be checked in an illuminated area, but this is meant solely for testing the device; the lens cap (2) must tightly cover the objective lens.
- To adjust the brightness of the red reticle, turn knob (4).
- To select one of the five (three - if EPM66G-2 tube employed) types of red reticles, press button (5).
- Choose a removed stationary object to observe, at a distance of about 100 m.
- Turn the focusing knob (6) to “100”, it will settle into a notch.
- Observe the object through the scope and turn the diopter focus knob (7) until the image appears crisp.
- If necessary, turn on the IR illuminator by turning the selector switch (3) to “IR” position.
- Turn the knob of the IR illuminator (8) until you get a focused IR spot.
- After making these adjustments, no further tuning of the diopter is required, regardless of distance or other factors; perfect the image quality using only the knob for the objective lens (6) and that for the IR illuminator (8).

- When finished, turn off the riflescope by turning the selector switch (3) to the “OFF” position and replace the objective lens cap (2).
- It is possible to mount the scope onto the firearm using a special bracket (9); after the initial mounting is performed, it is important to follow further mounting instructions in the section entitled “SIGHTING IN THE PHANTOM”.
- The riflescope can be turned on instantaneously with either the remote control housed in its bracket (10) or by button (11).

SIGHTING IN THE PHANTOM

Sighting in of the scope should be done at operating temperatures, by following the order of these steps:

- Mount the rifle with the scope installed on a scoped machine.
- Make sure that no sources of light are visible through the scope's field of vision.
- Set a target at a distance of about 100m; the light levels around the target should not exceed 1 lux.
- Remove the objective lens cap (2), by sliding it up on top of the objective lens.
- Turn on the scope by turning the selector switch (3) to the “ON” position.
- Aim the firearm at the target using the mechanical sight.
- Adjust the scope according to the steps in the section entitled “OPERATING THE PHANTOM”.
- Turn the objective lens focusing knob (6) until you get a crisp image of the target.
- Set the desired reticle brightness level by turning knob (4).
- If the center of the reticle crosshairs and the target center do not line up, remove the covers protecting the windage/elevation adjustment knobs.
- Using live ammunition, take 3 or 4 control shots, continually aiming at the same hit point on the target (you may also use a laser bore sighter and align the laser point to the center of the cross hairs).
- Examine the target and determine if the aiming point coincides with point of impact, if you determine it's necessary to make corrections, you will need to adjust your aiming point. To move it downwards and to the left, turn the knob (13) counterclockwise, in the directions Down and Left respectively, the aiming point moves upwards and to the right; keep in mind that one click of the knob corresponds to a 20mm shift of the hit point at a distance of 100m.
- Check the accuracy of your adjustments by firing another 3 or 4 control shots.
- The scope should now be zeroed-in for the specified distance.

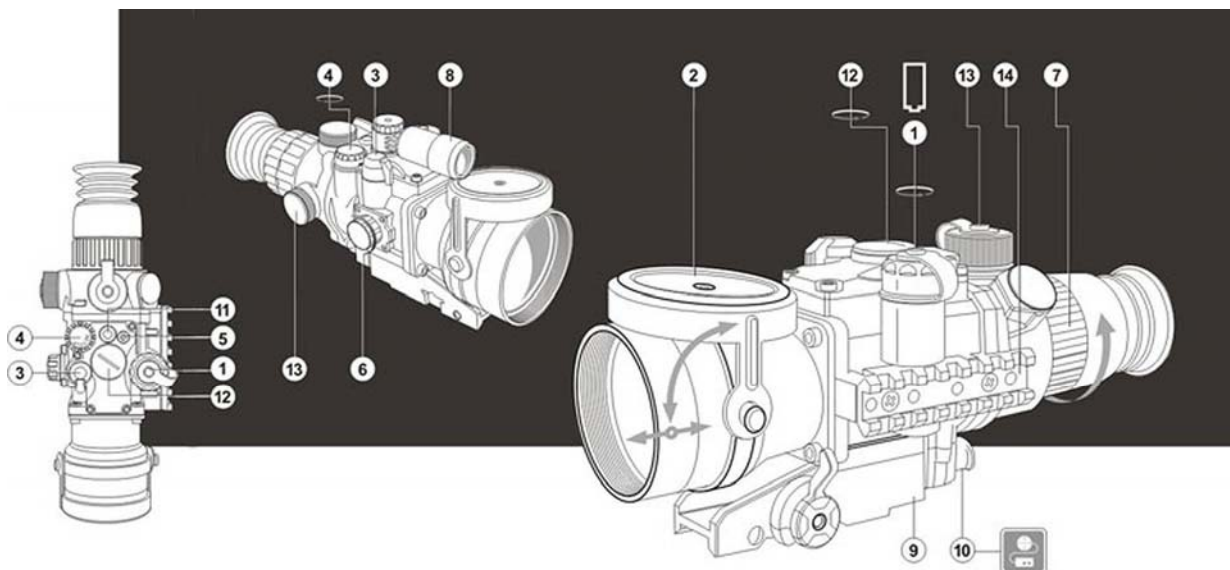

MIL-DOT RETICLE

Your night vision riflescope Phantom has a Mil-Dot reticle installed which helps you determine distance to the target if you know its actual size.

The Use of a Mil-Dot reticle:

Viewing the target through the riflescope place the edge of one post against one edge (top, bottom, or either side) of the target so that the crosshair extends along either its width or height.

Using the dots, measure along the crosshair to the opposite edge of the target.

Once the measurement of the target has been estimated in mils, use the following formula to determine the range:

The Measured object's width or height in Yards x 1000 = Range in Yards

Object's Width or Height in Mils

or

The Measured object's width or height in Meters x 1000 = Range in Meters

Object's Width or Height in Mils

or

The Measured object's width or height in cm x 10 = Range in Meters

Object's Width or Height in Mils

Example:

$$\frac{1.33 \text{ yards} \times 1000}{2.5 \text{ mils}} = \frac{1330}{2.5} = 532 \text{ Yards}$$

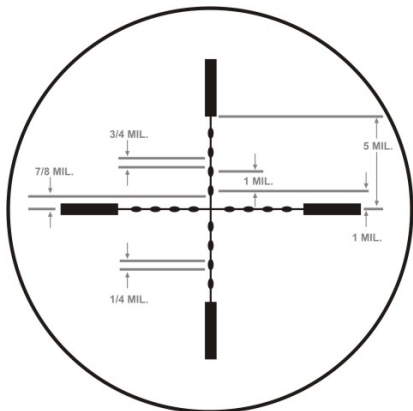

When making windage/elevation adjustments please note that one click of the riflescope's adjustment equals to:

For the model Phantom 3x50:

0.527 MOA (minute of angle); 0.5519"/100yds ; 1.533cm/100m

For the model Phantom 4x60:

0.4235 MOA ; 0.4435"/100 yds; 1.232cm/100m

1 mil (millirad) equals 3.6 inches at 100 yards or 36 inches at 1,000 yards,
or 10 centimeters at 100 meters or 1 meter at 1,000 meters.

1 millirad (1 mil) = 0.001 of the distance = 3.4377 MOA

Further information on the use of the Mil-Dot reticle (reference charts, calculators etc.) you can find at the following links:

<http://www.mildot.com>

http://www.mil-dot.com/Mil_Dot_User_Guide.htm

<http://www.shooterready.com/mildot.swf>

TECHNICAL INSPECTION

It is recommended to inspect the riflescope before every use. Make sure to check for the following:

- Visually inspect the unit is free from any physical damage; cracks, dents or signs of corrosion disqualify it from proper use.
- Check the sturdiness and proper fit of the mounting system.
- Ensure the condition of the objective lens, eyepiece and the IR illuminator are free of cracks, grease spots, dirt, water stains and other residue before use.
- Visually inspect the condition of the battery and the battery compartment; the battery should be free of electrolyte and oxidation residue, especially where the battery makes contact with metal.
- Verify the proper function of the following; selector switch (3), reticle brightness knob (4), reticle selector button and the instant power-on button (11).
- Verify the smoothness of the objective lens focusing mechanism (6), diopter focusing knob (7) and the IR illuminator knob (8).

TECHNICAL MAINTENANCE

Technical maintenance should be done no less than twice a year, and is comprised in the following steps:

- Clean the outside metallic and plastic surfaces from dust, dirt and moisture; wipe the scope with a soft cotton tissue, lightly coating it with gun oil or petroleum jelly.
- Clean the battery compartment's electric contact points using an oil-free solvent.
- Inspect the eyepiece lens, the objective lens and the IR illuminator and gently blow off any dust and sand, and clean using lens cleaner and a soft cloth; see section entitled **“GUIDELINES FOR OPERATION”**.

USING THE DIGITAL CAMERA ADAPTER

In order to conduct photo- and video recording please purchase a digital camera adapter accessory (#29023). Secure your Phantom to the included Weaver rail, refer to the manual for the camera adapter for further operation.

USING THE NVRS 2.5X50 ATTACHMENT

The NVRS 2.5x50 attachment (#29091) increases the magnification power of the 50mm PHANTOM 1.7 times.

The attachment screws into the internal groove of the riflescope's objective lens; refer to the instruction manual for the NVRS 2.5x50 when installing. A possible shift of the aiming point may occur and, in that case, it is important to sight in the scope as previously described.

USING THE ADDITIONAL WEAVER RAIL

The scope has a built-in additional weaver rail mount (14) housed on the left portion of the body. This will allow the mount of additional devices, such as:

- The Yukon IR illuminator, with mount (#29072)
- The Yukon NVRS directional microphone with adapter (#27022)
- The Yukon laser sighting device (#27012)

STORAGE

Always store the unit in its carrying case in a dry, well-ventilated space. For prolonged storage, remove the batteries.

TROUBLESHOOTING

Listed below are some potential problems that may occur when using the PHANTOM. Carry out the recommended checks and troubleshooting steps in the order listed. Please note that the table does not list all of the possible problems. If the problem experienced with the scope is not listed, or if the suggested action meant to correct it does not resolve the problem, please contact the manufacturer.

Problem	Possible cause(s)	Corrective action
The scope will not start.	The batteries have been installed incorrectly.	Reinstall the batteries with the correct polarity orientation.
	The total battery charge is less than 1.0V (for AA) or 2.2 (for CR123).	Install fresh batteries.
	Oxidized contact points in the battery compartment due to “leaky” batteries or contact points becoming exposed to a chemically-reactive solution.	Clean the battery compartment, focusing on the contact points.
The red reticle is blurred and cannot be focused with the diopter knob.	The diopter cannot be adjusted to your vision.	If you wear prescription glasses with a range of more than +/- 5, keep glasses on when looking through the eyepiece.
With a crisp image of the reticle, the image of the observed target that is at least 30 m away is blurred.	Dust and moisture are covering the outside optical surfaces. Moisture is on the inside of the objective and the eyepiece lenses, or is on the optical surfaces of the electronic-optical converter and may be caused by the unit fogging up due to a rapid change in temperature; when the device is brought in from the cold into a warm environment, for example.	Clean the lens surfaces with a soft cotton tissue or cloth. Let the riflescope dry by leaving it in a warm environment for 4 hours.
	The total battery charge is less than 1.0V (for AA) or 2.2 (for CR123).	Install fresh batteries.
Distinct black dots or specs on the screen.	The dots on the screen are cosmetic blemishes in the intensifier tube and are a by-product of the manufacturing process; they do not in any way affect the life or performance of the unit, and if there is dust on the lens, please clean according to the instructions.	No need to take corrective action or return the device.
The scope or the	The scope is turned on via the	Turn off the scope and the IR

IR illuminator do not turn off via the selector switch on the scope.	remote control.	illuminator using the remote control.
The aiming point shifts after firing rounds.	The riflescope is not mounted securely.	Check how securely the riflescope has been mounted and make sure that the same type and caliber bullets are being used as when the scope was initially sighted in; if your scope was sighted in during the summer, and is now being used in the winter (or the other way around), a small displacement of the aiming point is possible.
The riflescope does not focus.	Wrong settings.	Adjust the riflescope according to the instructions given in the section, entitled "OPERATING THE PHANTOM" and check the surfaces of the eyepiece and objective lenses and clean them if necessary from dust, condensation, frost, etc; to prevent fogging in cold weather, apply a special anti-fog solution.